

# МАВЗОЛЕЙ ЗА ЕДИН ЖИВ СВЯТ

Примерен експозиционен план на проекта

## MAUSULEUM FOR A LIVING WORLD

Indicative exhibition plan of the project

Художник : **Иглика Христова**  
Куратор : **Мари-Лор Дежарден**  
Artist : **Iglika Christova**  
Curator : **Marie-Laure Desjardins**

ПРОЕКТ ЗА БЪЛГАРСКИЯ ПАВИЛИОН НА ВЕНЕЦИАНСКОТО БИЕНАЛЕ ПРЕЗ 2024 г.  
PROJECT FOR THE BULGARIAN PAVILION AT THE VENICE BIENNALE 2024

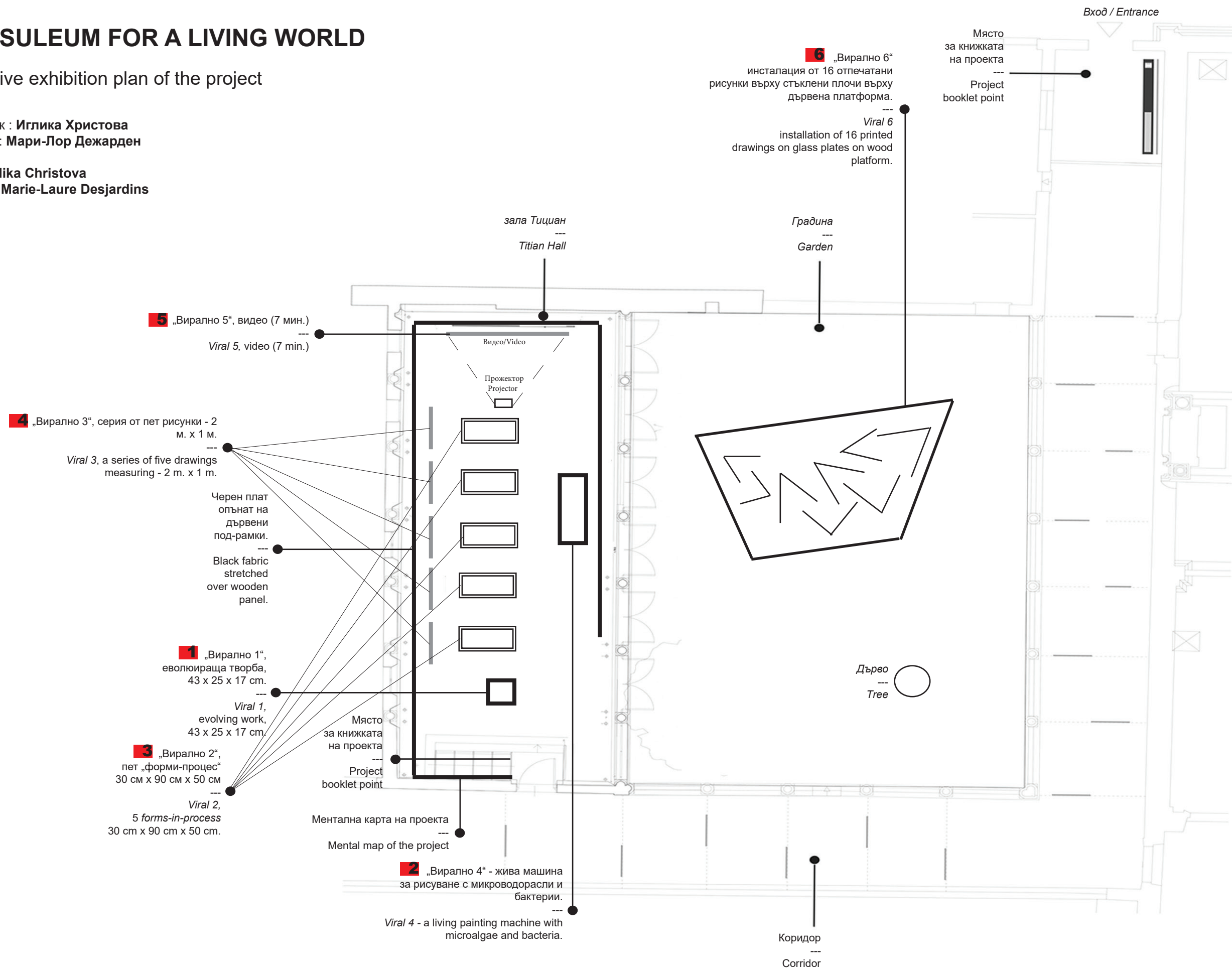



# МАВЗОЛЕЙ ЗА ЕДИН ЖИВ СВЯТ

Визуализация на произведенията в изложбеното пространство

# MAUSULEUM FOR A LIVING WORLD

Visualization of the manufactured in the exhibition space

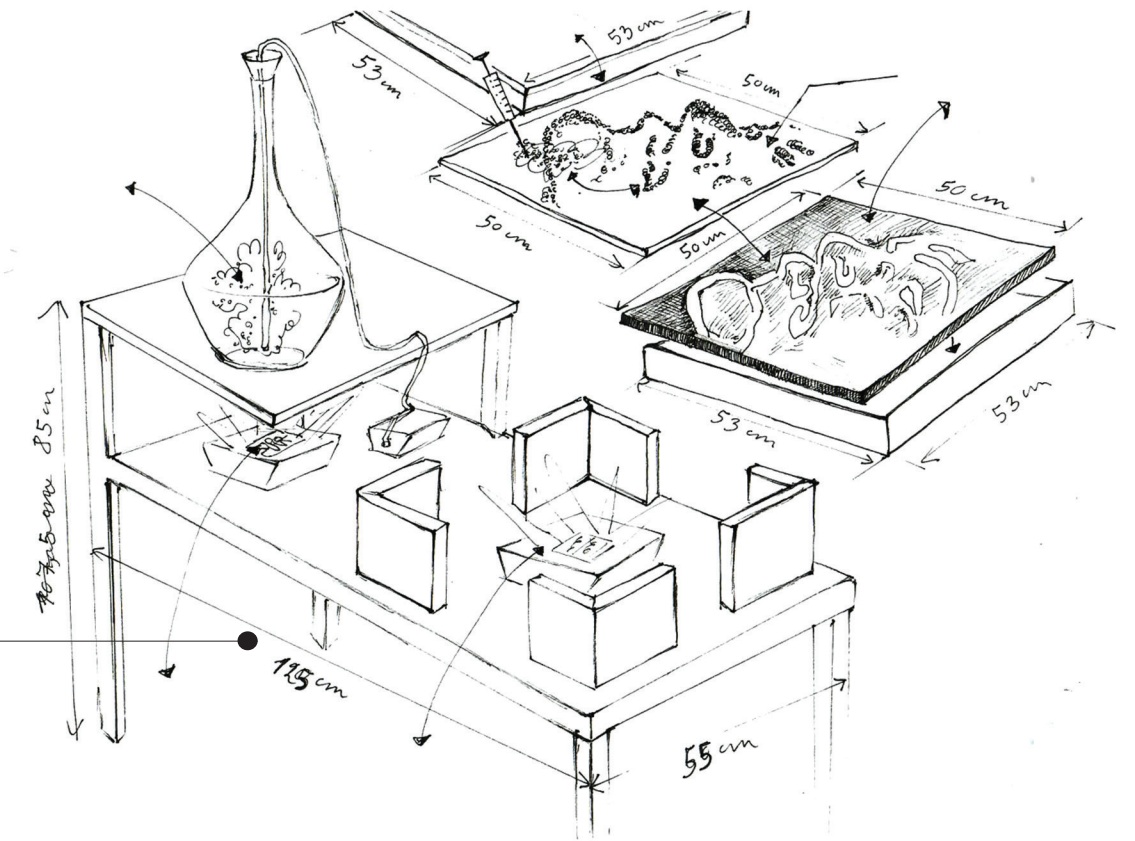
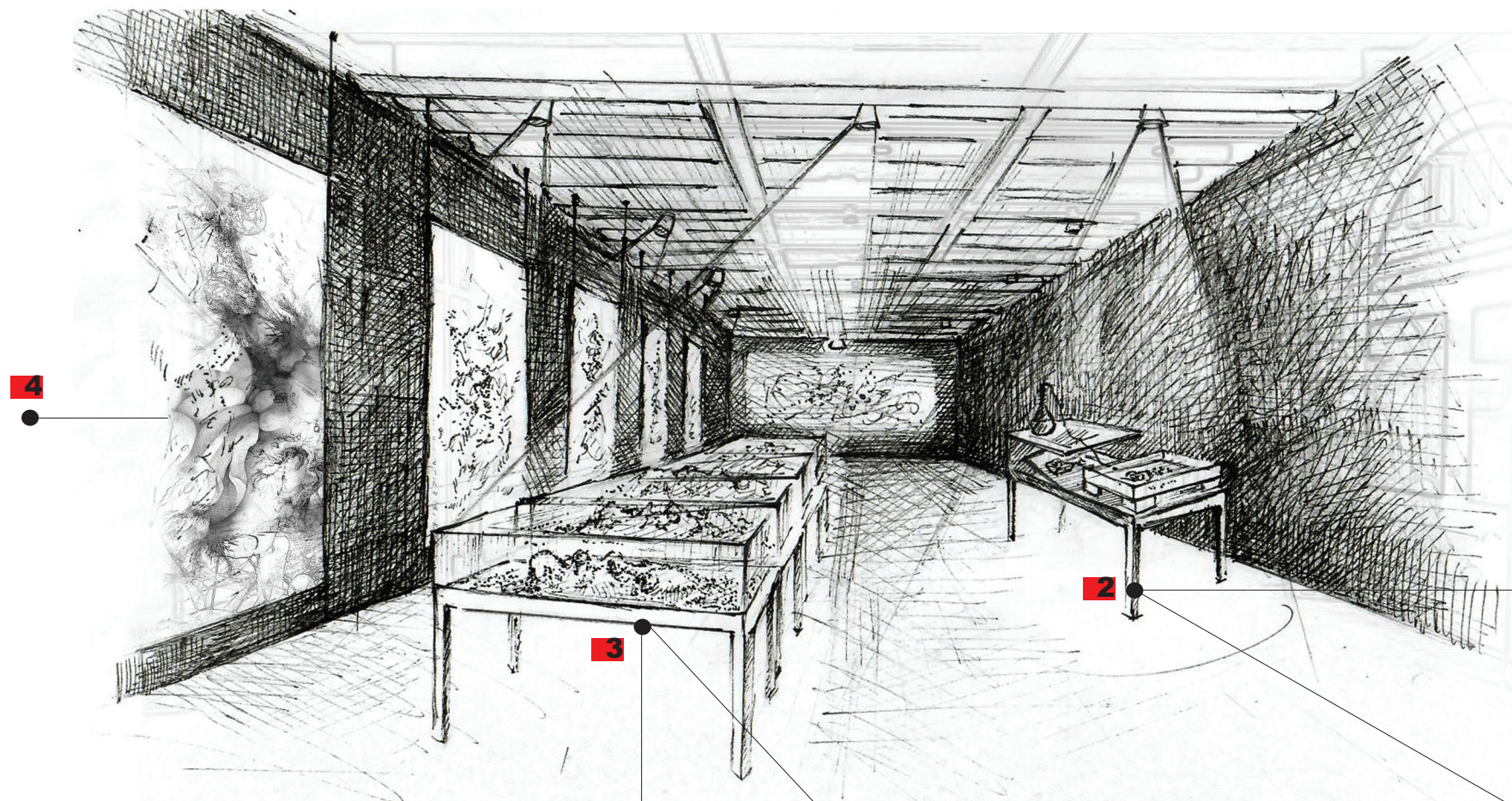

Номерата на произведенията отговарят на номерацията в примерния експозиционен план на проекта (стр. 1).

The numbers of the works correspond to the numbering in the indicative exhibition plan (page 1).

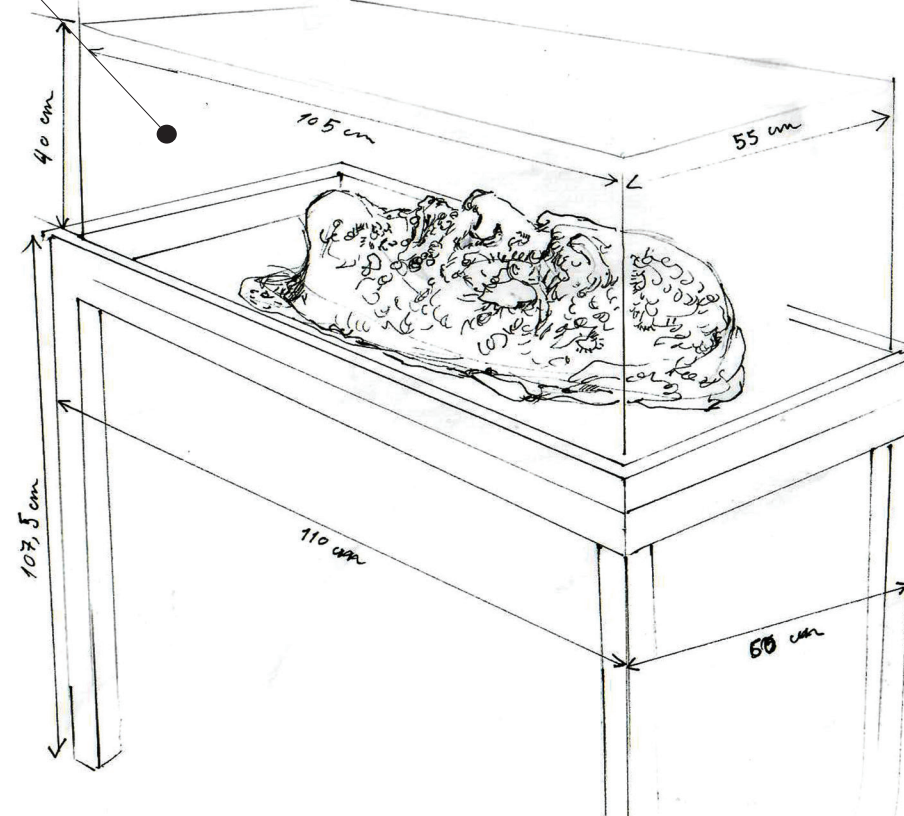
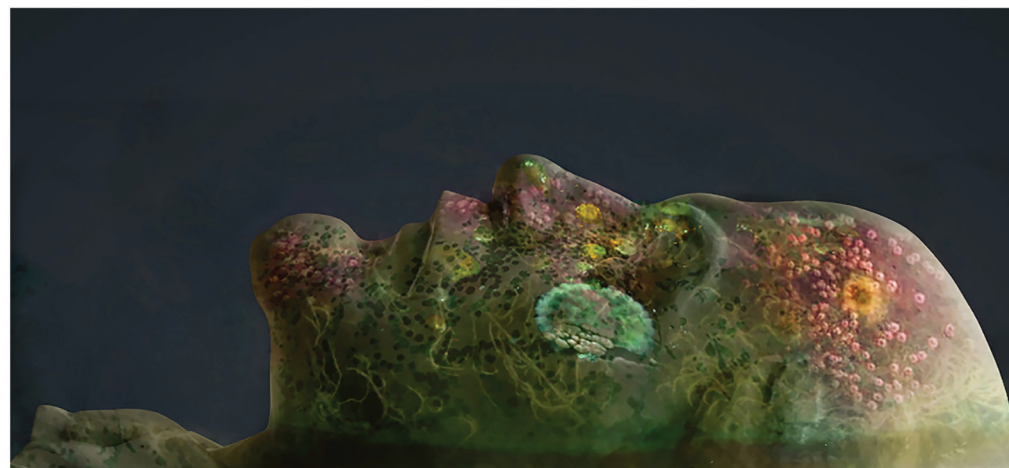



# МАВЗОЛЕЙ ЗА ЕДИН ЖИВ СВЯТ

Визуализация на произведенията в изложбеното пространство

---

# MAUSULEUM FOR A LIVING WORLD

Visualization of the manufactured in the exhibition space

Номерата на произведенията отговарят на номерацията в примерения експозиционен план на проекта (стр. 1).

---

The numbers of the works correspond to the numbering in the indicative exhibition plan (page 1).

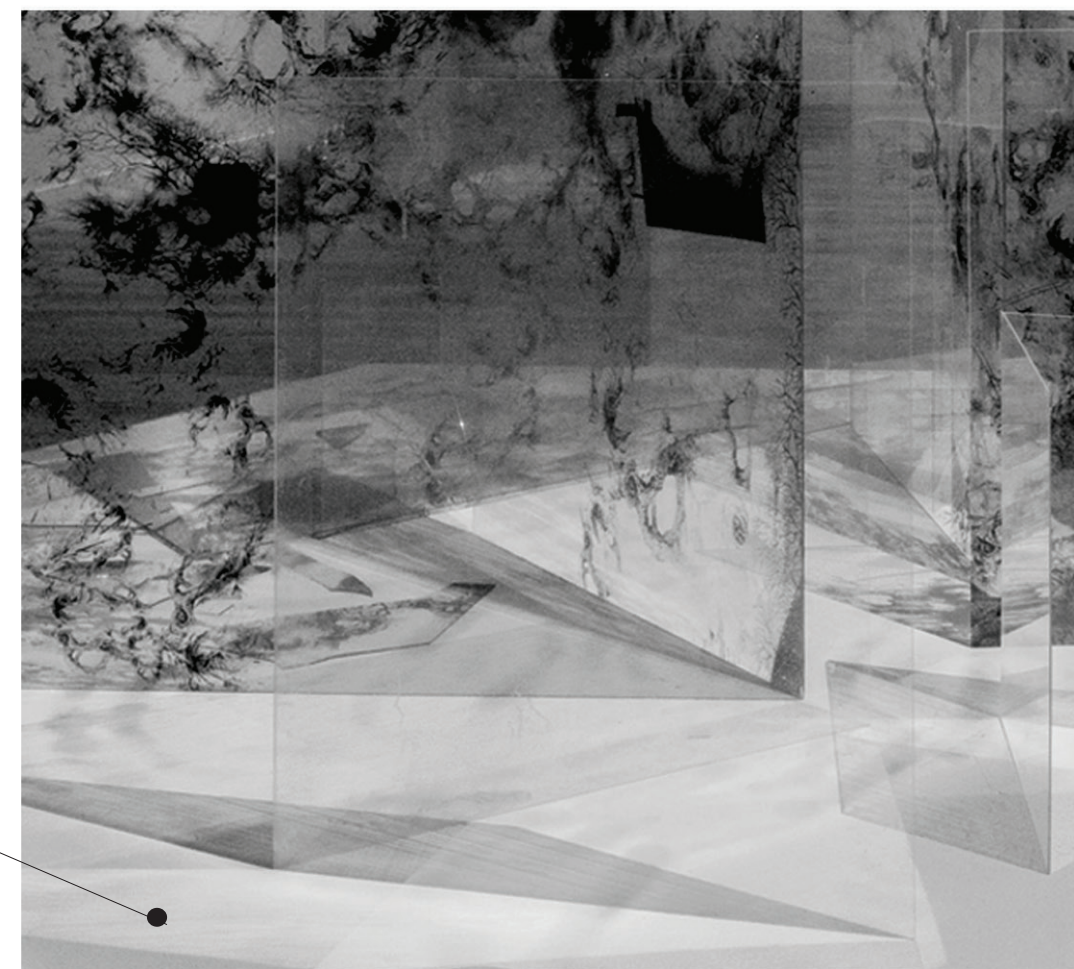



# МАВЗОЛЕЙ ЗА ЕДИН ЖИВ СВЯТ

Визуализация на произведенията в изложбеното пространство

# MAUSULEUM FOR A LIVING WORLD

Visualization of the manufactured in the exhibition space

Номерата на произведенията отговарят на номерацията в примерния експозиционен план на проекта (стр. 1).  
---  
The numbers of the works correspond to the numbering in the indicative exhibition plan (page 1).

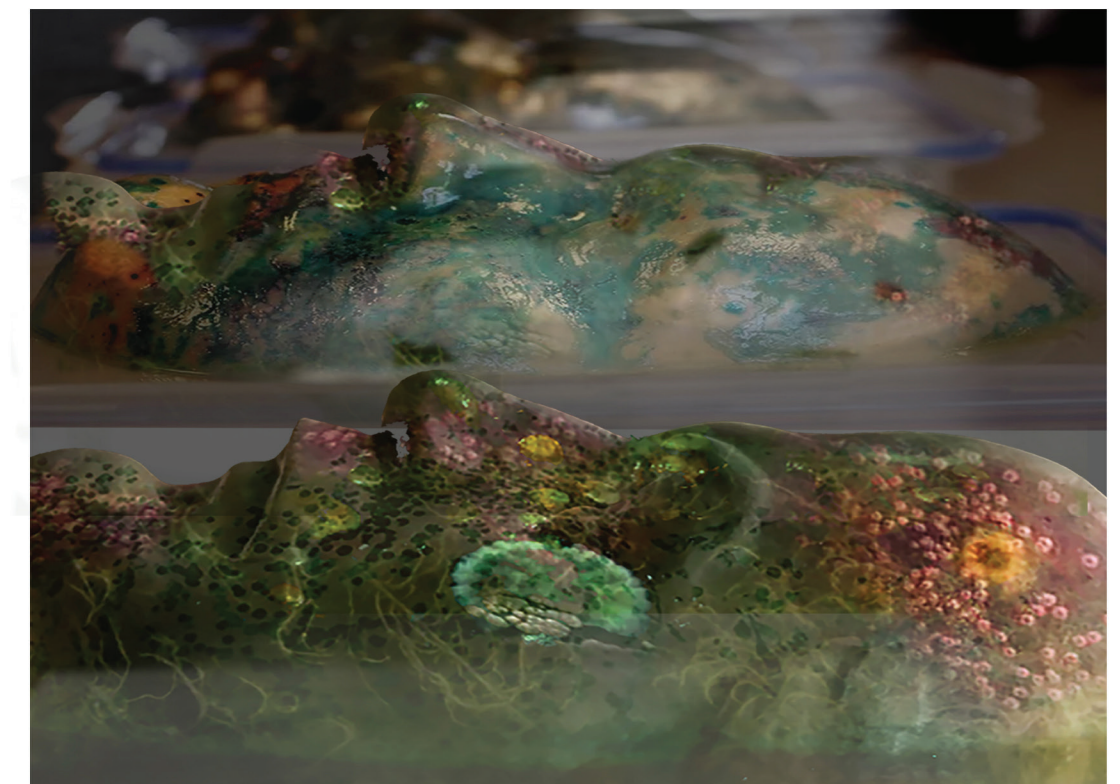
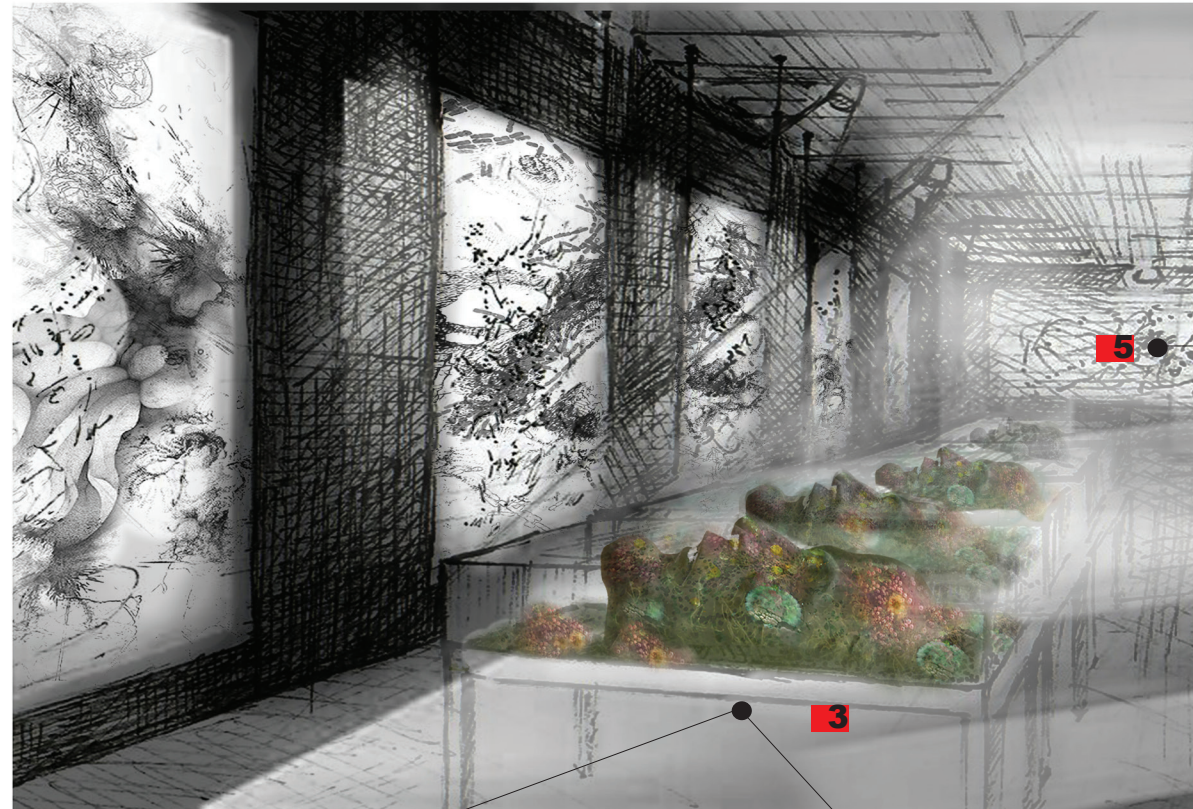



# МАВЗОЛЕЙ ЗА ЕДИН ЖИВ СВЯТ

Визуализация на произведенията в изложбеното пространство

# MAUSULEUM FOR A LIVING WORLD

Visualization of the manufactured in the exhibition space



1

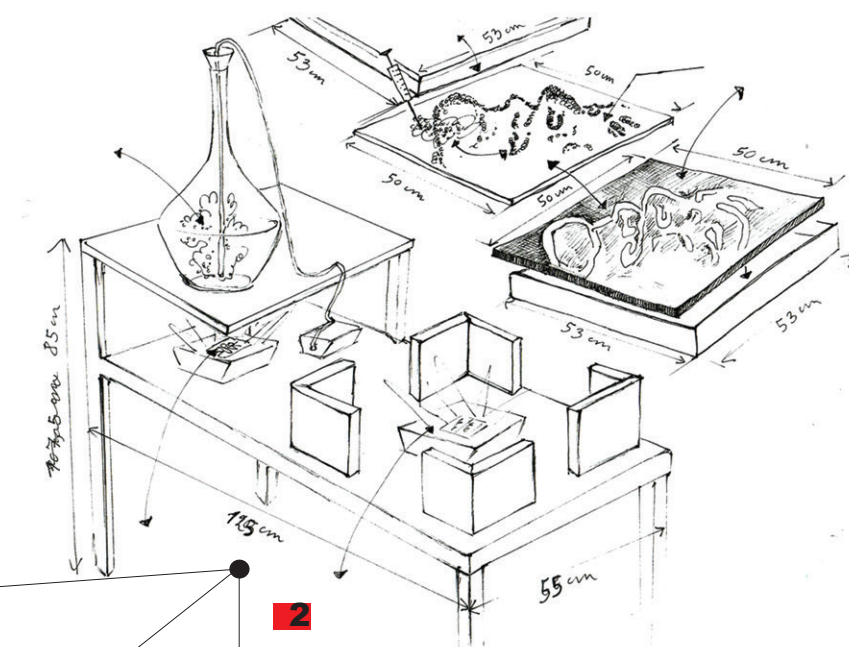

2

Номерата на произведенията отговарят на номерацията в примерения експозиционен план на проекта (стр. 1).

---  
The numbers of the works correspond to the numbering in the indicative exhibition plan (page 1).

